



Installation, Operation, Maintenance Disassembly and Assembly Instructions for Model A1590P Liquid Fill or Vapor Return Valve

June 2000

Form FVC 013 - Rev. 1

KEEP THIS DOCUMENT WITH THE PRODUCT UNTIL IT REACHES THE END USER.

WARNING

Before installation or removal of any tank valves, the system must be purged completely of all product. Use proper safety equipment at all times. An abundant supply of clean water must be readily available and easily accessible as a means of providing IMMEDIATE First Aid treatment of exposure to ammonia. To insure long term safe operation, the manufacturer recommends that under normal service conditions this product should be inspected at least once every five (5) years and be repaired or replaced as required. To prevent the accidental opening of any valve, never carry or grasp a valve by its handwheel or handle.

CAUTION: Contact with or inhalation of Liquid Anhydrous Ammonia or LP-Gas or their vapors can cause serious injury or death. Dispersment must be in accordance with local regulations.
For the proper handling and storage of Anhydrous Ammonia refer to ANSI Standard K61.1
For the proper handling and storage of Liquefied Petroleum Gas refer to NFPA Pamphlet 58.

TOOLS REQUIRED: Safety Equipment (i.e. gloves, goggles, and clothing), 12" Adjustable Wrench, 7/16" Open End Wrench & 18" Pipe Wrench

Removal of Tank Valve for Repair or Replacement

REFER TO FIGURE 1 FOR THE FOLLOWING STEPS:

- Step 1: Safety equipment (i.e. gloves, goggles and clothing) must be worn before continuing with the next step.
- Step 2: Before removing valve from tank, place in FULL OPEN POSITION to insure all pressure is bled from system.
Note: An 18" Pipe Wrench will be required. See Warning at top of page.

Disassembly Procedure for Repair

REFER TO FIGURE 1 FOR THE FOLLOWING STEPS:

- Step 1: With valve secured in a bench vise, remove Bonnet (5) from the Body (19), which will expose the complete Bonnet and Stem Assembly.
Note: It is important to inspect Disc Holder (9) rotation. If it does not rotate freely, do not use valve. Consult your local dealer for instructions.
- Step 2: Secure Bonnet (5) in a bench vise and remove both Handwheel and Disc Nuts (1).
- Step 3: Remove Disc Washer (11), Disc (10), Handwheel (2) and Info-Disc (12).
- Step 4: Remove Packing Nut (4), Chevron Packing (14), Male Adapter (15), and Packing Spring (17) over the end of Stem (3).
- Step 5: Rotate Stem (3) clockwise (CW) using Handwheel (2) if necessary, until stem is disengaged from Bonnet (5).

Assembly Procedure

DEGREE OF ASSEMBLY DEPENDS UPON TYPE OF REPAIR TO BE MADE.

REFER TO FIGURE 1 FOR THE FOLLOWING STEPS:

- Step 1: Install Disc (10), Disc Washer (11), and Disc Nut (1) to Disc Holder (9). Secure Disc Nut (1) to threads of Disc Holder (9) with center punch mark at thread interface.
- Step 2: Lubricate threads of stem with a good quality grease and install Stem (3) into Bonnet (5) until Disc Holder (9) rests against bottom of bonnet.
- Step 3: With the bonnet and stem assembly secured in a bench vise install Gasket (16) and Packing Spring (17).
- Step 4: Replace O-ring (13) in groove of Packing Nut (4).
- Step 5: Install Chevron Packing (14) and Male Adapter (15) into Packing Nut (4).
- Step 6: Lubricate exposed surface of Stem (3) with John Crane Style 279A Packing Lubricant or equal.
- Step 7: Place Packing Nut (4) with packing in place over Stem (3) and engage bonnet threads in Bonnet (5). Rotate Packing Nut (4) while making contact with bonnet threads. Tighten packing nut with torque wrench to 55 ft-lbs.
- Step 8: Secure Body (19) in vise. Place Body Gasket (18) over bonnet threads and lubricate threads with a good quality grease.
- Step 9: Install bonnet assembly into body and tighten with torque wrench to 95 ft-lbs.
- Step 10: Install Handwheel (2), Info-Disc (12) and tighten Handwheel Nut (1) on Stem (3).
- Step 11: Check stem packing and valve seat for leaks. Operate handwheel full open to full closed to insure smooth operation.

(OVER)

Step 1: The Excess Flow Assembly is a safety device which will “slam shut” in the event of a hose failure, i.e. a pull-away or accident which causes the hose to be severed completely. It is of utmost importance that this assembly operate properly. Please read and understand Excess Flow Valve Technical Bulletin 7.96. If you do not have a copy you may contact your local distributor or Squibb-Taylor at 1-800-345-8105.

- a.) **TO INSPECT:** Place the palm of the hand against the hex head of Check Stem (22) and depress Spring (23) until Check Disc (24) is at full stroke against the Valve Body Seat (A). Release the Check Stem (22), and observe the spring return stroke. If the excess flow assembly does not move freely toward Body Seat (A) or exhibit a snap action on the spring return stroke, **it must be replaced.**
Note: The complete excess flow valve assembly number is S1590-1100.
- b.) **TO REMOVE:** Secure the valve body in a bench vise and using a 12" adjustable wrench rotate the Excess Flow Assembly (7) counter-clockwise (CCW) to remove from Valve Body (19).
- c.) **TO REPLACE:** Clean the internal body threads with a wire brush or solvent and wipe or blow dry with air. Apply the loctite thread adhesive, part # TL 29005 provided with the Excess Flow Assembly kit to the Yoke (7) and body threads. Install the new Excess Flow Assembly into the body and tighten with the 12" adjustable wrench.

CAUTION: Do not allow loctite to contact the stem or check disc. Allow 30 minutes to dry and check operation of assembly per a.) above.

Step 2: Before reassembly, clean and inspect the valve seat at (B). Clean all metal components with solvent and wipe or blow dry with air.

Installation of New or Repaired Tank Valves

REFER TO FIGURE 1 FOR THE FOLLOWING STEPS:

- Step 1: Holding the valve in hand, depress and release Check Stem (22) to insure that it is operating smoothly.
- Step 2: Apply Teflon tape or sealant on 1-1/4" NPT threads, and place handwheel in full open position.
- Step 3: Install valve into threaded tank fitting and tighten to desired position, taking caution to not overtighten.

CAUTION: Do not damage Check Stem (22) while installing valve.

Safety Tips for Shut-down and Storage

SAFETY TIPS FOR SHUT-DOWN AND STORAGE WHEN TANKS ARE NOT IN USE:

- Step 1: Make sure all valves are closed with any exposed outlets / inlets capped to keep out debris and moisture, which will help to prevent condensation or corrosion of internal parts.
- Step 2: Store tanks in accordance with federal, state, and local codes and manufacturer's instructions. Check periodically for leakage or excessive pressure build-up. Make corrections or repairs as necessary.

27	1	WARNING LABEL
26	1	ACME CAP
25	1	GASKET
24	1	CHECK DISC
23	1	SPRING
22	1	CHECKSTEM
21	1	1/4" NPT HEX HD. PLUG
20	1	RETAINING SCREW
19	1	BODY
18	1	BODY GASKET
17	1	PACKING SPRING
16	1	GASKET
15	1	MALE ADAPTER
14	2	CHEVRON PACKING
13	1	O-RING
12	1	INFO-DISC
11	1	DISC WASHER
10	1	DISC
9	1	DISC HOLDER
8	15	BALL
7	1	YOKE
6	1	LOCTITE PACKAGENS
5	1	BONNET
4	1	PACKING NUT
3	1	STEM
2	1	HANDWHEEL
1	2	HANDWHEEL NUT/DISC NUT
ITEM	QTY	DESCRIPTION

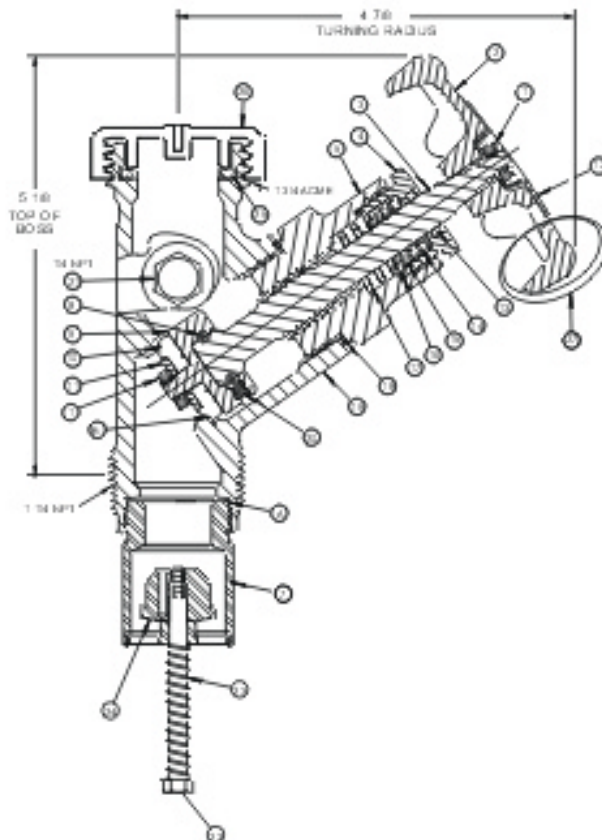

FIG 1

AVAILABLE KITS		
NUMBER	NAME & PARTS INCLUDED	ASSEMBLY PROCEDURE
310-0022	SEAL KIT 3 13 19 22 19 23	STEPS 1 THRU 11
310-1300	STEM & DISC HOLDER ASSEMBLY 3 4 5 6 7 8 9 10 11 12 13 14 15 16 17 18 19 20 21	STEPS 2 THRU 11
310-1100	BONNET ASSEMBLY 1 2 3 4 5 6 7 8 9 10 11 12 13 14 15 16 17 18 19 20 21 22 23 24 25 26 27	STEPS 8 THRU 11
S1597-1100	EXCESS FLOW ASSEMBLY 1 2 3 4 5 6 7 8 9 10 11 12 13 14 15 16 17 18 19 20 21 22 23 24 25 26 27	SEE DIRECTIONS FOR EXCESS FLOW REPLACEMENT