

Chandler Spreaders, Inc.
Gainesville, Georgia
Quality Fertilizer Equipment

AT-FTLH EXW



For more information contact us at 1-800-243-3319 or visit our website: www.chandlerspreaders.com

Chandler Spreaders, Inc.

Gainesville, Georgia
Quality Fertilizer Equipment

AT-FTLH EXW

"Specifications"

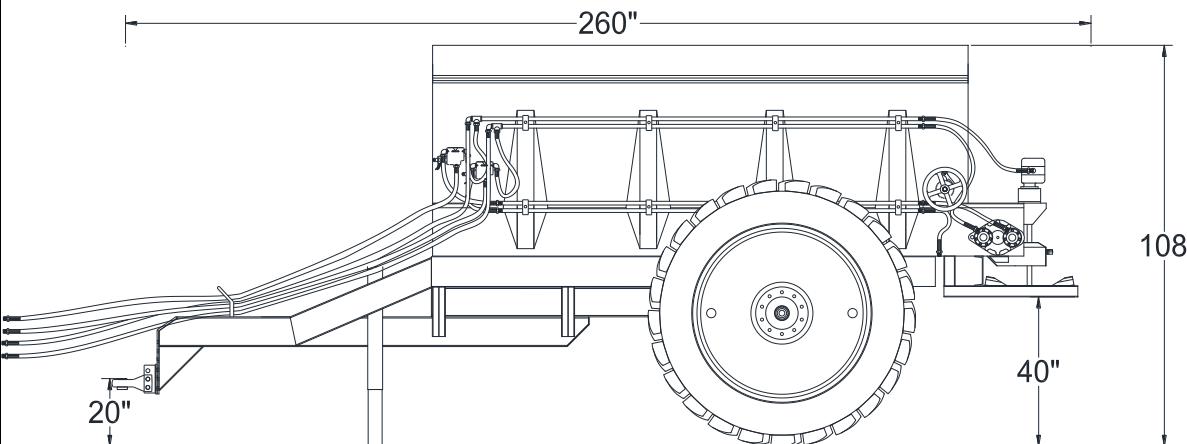

All Products and Specifications are subject to change without notice.

	<u>Fertilizer @ 65 #</u>	<u>Lime @ 90 #</u>
Hopper Capacity (Struck Level)	280 Cu. Ft.	
Payload (struck level)	18,220Lbs.	24,000 Lbs
	Maximum Recommended Capacity	

Warning: Use 120" Track for Fertilizer ONLY!
Use 90" Track or Less When Spreading Lime

Hopper Construction:

Available in three types of material: Mild Steel, 409 Stainless Steel, and 304 Stainless Steel

Conveyor Specs:

Available in: Bar Type Chain and Belt Over – Bar type Chain

Spinner Specifications:

4- Blade configuration with dished type spinners and a specially designed flow divider for wide swath applications. (50' Lime – 80' Fertilizer)

High Pressure, Double Bearing spinner motors mounted overhead keeps motors out of fertilizer and other contaminants for longer life.

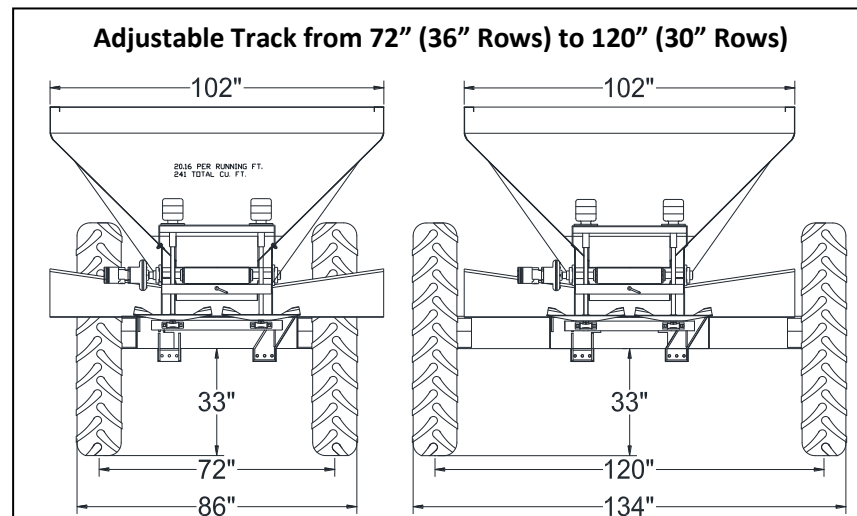

Spread Patterns:
Fertilizer up to 80 - Lime up to 50'

Adjustable Track Axle 72" -120"
380/65R – 46 Tires

For more information contact us at 1-800-243-3319 or visit our website: www.chandlerspreaders.com