

(214) 357-4591 DALLAS TEXAS (800) 345-8105

MANUFACTURED BY PGI INTERNATIONAL

Installation, Operation & Maintenance Manual Disassembly and Assembly Instructions for Models AL343 & AL362

Nov 2010

Form FVC 036 - Rev 04

KEEP THIS DOCUMENT WITH THE PRODUCT UNTIL IT REACHES THE END USER.

WARNING

Use proper safety equipment at all times.

Before installation or removal of any globe or angle valve, the system must be purged completely of all product. An abundant supply of clean water must be readily available and easily accessible as a means of providing IMMEDIATE First Aid treatment for exposure to ANHYDROUS AMMONIA. To prevent the accidental opening of any valve, never grasp or carry a valve by its handwheel or handle.

This equipment must be installed, operated and maintained in accordance with federal, state and local codes and manufacturer's instructions. For LP-Gas service, follow NFPA/ANSI 58 Standard for the storage and Handling of Liquefied Petroleum Gases, plus all Local and State Safety Regulations. In addition, in most states the installation must also comply with ANSI K61.1 standards. Only personnel trained in the proper procedures, codes, standards and regulations should install, inspect, repair and/or replace this equipment. Failure to follow these instructions or to properly install and maintain this equipment could result in property damage and/or personal injury or death.

To ensure long term safe operation, the manufacturer recommends that under normal service conditions, this product should be inspected at least once every two (2) years and be repaired or replaced as required.

CAUTION: Contact with or inhalation of Liquid Anhydrous Ammonia or L-P Gas or their vapors can cause serious injury or death. Dispersement must be in accordance with local regulations.
For the proper handling and storage of Anhydrous Ammonia refer to ANSI Standard K61.1.
For the proper handling and storage of Liquefied Petroleum Gas, refer to NFPA Pamphlet 58.
NOTE: If used in N-Serve applications, inspect the valve seat before each usage season and replace if hardened or cracked.

TOOLS REQUIRED: Safety Equipment (i.e. Gloves, Goggles, and Clothing), 12" Adjustable Wrench, 1/4" Diameter Drift Pin, small Ball Peen Hammer, 7/16" Open-End or Boxed-End Wrench, and Center Punch

Removal of Valve for Repair or Replacement (Refer to Figure 1 for Item Numbers)

Step 1: Safety equipment (i.e. gloves, goggles, and clothing) must be worn before proceeding to the next step.

Step 2: Before removing the valve from the tank, place the valve in the **FULL OPEN POSITION** to ensure all pressure is bled from the system. See WARNING at the top of this page.

Disassembly Procedure for Repair (Refer to Figure 1 for Item Numbers)

Step 1: With the valve secured in a bench-mounted vise, use the 1/4" Drift Pin to remove the Roll Pin 28. This will allow the Handle Assembly to be removed from the Stem 16.

Step 2: Remove the Bonnet 20 from the Body 12 using the 12" Pipe Wrench.

NOTE: The Handle Bearing 25, Wiper Ring 26, Seal Washer 24, Stem Seal 22, Seal Sleeve 23, Seal Retainer 21, and Body/Bonnet Seal 15 will all remain with the Bonnet when removed.

Step 3: Remove the Stem and Extension Assembly through the top of the Body 12.

NOTE: The Stem Spring 17, Stem Centering Bushing 19, and Handle Guide 27 will all remain with the Stem and Extension Assembly when removed. Keep these parts for use during re-assembly.

CAUTION: The complete Stem and Extension Assembly should be inspected before re-assembly is attempted. The following components should be inspected for proper fit and function before the Stem and Extension Assembly is re-used.

1. At Location "A" of FIGURE 1, the Stem Extension 10 must rotate freely inside the Stem Extension Guide Nut 13 and have a small amount of end play inside the bore of the Stem 16. This interface is mechanically crimped and cannot be disassembled.
2. At Location "B" of FIGURE 1, the Disc Holder 9 should be shouldered snug against the Hex Jam Nut 2.

If inspection of either of these locations yields a problem, the complete Stem and Extension Assembly must be replaced. Refer to the Available Kits Chart on the reverse side for Kit Numbers.

Assembly Procedure (Refer to Figure 1 for Item Numbers)

Step 1: Before removing the Disc 1, take note of the location and depth of the "staking" at the top of the Hex Jam Nut 2. To remove the Disc from the Disc Holder 9, remove the Hex Jam Nut and the Disc Washer 3.

Step 2: Re-assemble the valve using a new Disc 1 and a new Hex Jam Nut 2. Never re-use the old Jam Nut.

NOTE: The Hex Jam Nut must be tightened snug against the Disc Washer and then "staked" using a Center Punch on top of the Nut at the same location and depth as the original assembly.

Step 3: To replace the Stem Seal 22, remove the Handle Bearing 25 and Wiper Ring 26 from the top of the Bonnet 20. Keep these parts for use during re-assembly. Through the top of the Bonnet, press the Seal Washer 24 downward using the 1/4" Drift Pin. This will also remove the Stem Seal 22, Seal Sleeve 23, and Seal Retainer 21. Remove the Bonnet/Body Seal 15.

Step 4: To install the new Stem Seal and re-assemble the valve, place the repaired Stem and Extension Assembly (or new Assembly Number S343-1702) through the top of the Body 12 until it rests on the Seat 4.

Assembly Procedure (cont'd.)

- Step 5: Place the Stem Centering Bushing ⑭ over the Stem ⑬ so that it rests on the lip at the bottom of the Stem. Install the Stem Spring ⑰ and Seal Retainer ⑳ over the Stem ⑬ with the small shoulder diameter of the Seal Retainer ⑳ facing upward.
- Step 6: Place the Stem Seal ㉒ over the Seal Sleeve ㉓ to create a "Seal Assembly". Lubricate the Seal Assembly with the Dow Corning 112 grease provided in the Seal Kit. With the flange of the Seal Sleeve facing upward, place the Seal Assembly over the Stem ⑬ and carefully press it down until it touches the small shoulder diameter of the Seal Retainer ⑳. Install the Seal Washer ㉔ over the Stem ⑬ with the larger shoulder facing downward.
- Step 7: Install the Body/Bonnet Seal ⑮ to the Bonnet ㉑ and lubricate the seal with the Dow Corning 112 grease provided. Carefully place the Bonnet over the Stem and press down until the threads on the Bonnet engage the threads in the top of the Body. Thread the Bonnet down to the top shoulder of the Body and tighten snug with a 12" Adjustable Wrench.
- Step 8: Install the Wiper Ring ㉖, with the larger shoulder downward, into the groove on top of the Bonnet and re-install the Handle Bearing ㉕.
- Step 9: Install the Handle Pivot Roll Pin ㉚ into the hole on just one side of the Handle ㉙. Place the Handle Guide ㉗ over the Stem with the large diameter of the Handle Guide facing downward. Re-install the Handle Assembly (or new Assembly Number S340-1300) over the Stem. Align the Roll Pin with the hole in the Stem and drive it through with a Ball Peen Hammer.

The valve is now assembled and ready for a Mechanical Latch Test and a Pressure Test.

LATCH TEST:

Spin the Handle Assembly around the top of the valve three times. Open and close the Handle Assembly three times. To close, strike the top of the Handle and allow the valve to snap shut. After each closing, be sure the Handle Safety Lock ⑱ latches underneath the Bonnet ㉑ flange. Pull upward on the Handle each time to ensure that the valve cannot be opened unless the Handle Spring ㉙ is depressed.

This is an important Safety Feature and will ensure that the valve cannot be accidentally opened when under pressure.

PRESSURE TEST:

After the repair is complete and with the valve in the CLOSED position, the Valve Seat ④ and the Stem Seal ㉒ should be "bubble tight" when pressurized at the inlet to 75 psig (air) and submerged in water.

Installation of a New or Repaired Quick Acting Valve

- Step 1: Apply Teflon tape or sealant on the male threads of the hose or other mating part.
- Step 2: Install the Valve and tighten to the desired position, taking care not to over-tighten.

Operation of the Quick Acting Valve

- Step 1: To open the Valve, press downward on the flat surface of the Handle ㉙, directly over the Handle Spring ㉙, and lift the Handle to a vertical position. When the Valve is in the full OPEN position, the heel of the Handle will rest squarely on the Handle Bearing ㉕, with the Handle being "cammed over" slightly past the center of the Valve.
- Step 2: To close the Valve, tap the Handle in the closing direction with the heel of your hand. The Handle will release in a "Quick Acting" manner to the CLOSED position. The closing spring action of the valve assembly is designed to force the Handle Safety Lock ⑱ to secure itself beneath the Bonnet ㉑ flange, therefore preventing accidental opening of the Valve.

WARNING: If the Valve is closed slowly by holding the Handle as it is moved toward the CLOSED position, be sure the Handle reaches its STOP position. The Handle Safety Lock must engage beneath the Bonnet flange.

AVAILABLE KITS		
Kit Number	Kit Name & Items Included	Assembly Procedure
343-0022	Seal Kit ① ② ⑮ ⑰ ⑱ ㉒ ㉓ ㉔ ㉕	Steps 1 thru 9
S340-1300	Handle Assy. ⑱ ⑲ ㉚ ㉙ ㉛ ㉜	Step 9
S343-1702	Stem & Extension Assy. ② ③ ⑨ ⑩ ⑬ ⑭ ⑯	Steps 4 thru 9

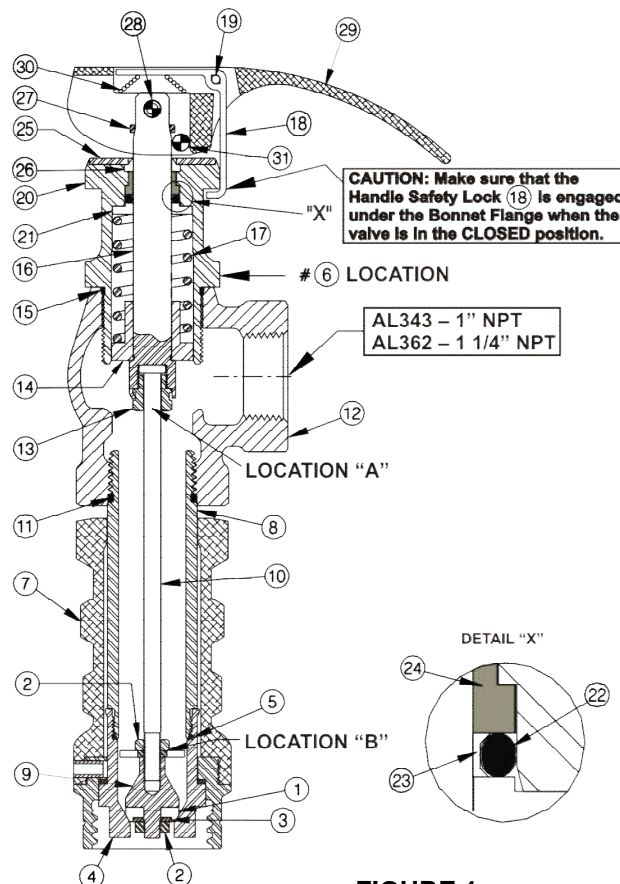

FIGURE 1

31	1	Spiral Pin
30	1	Handle Spring
29	1	Handle
28	1	Handle Pivot Roll Pin
27	1	Handle Guide
26	1	Wiper Ring
25	1	Handle Bearing
24	1	Seal Washer (In Detail "X")
23	1	Seal Sleeve (In Detail "X")
22	1	Stem Seal (In Detail "X")
21	1	Seal Retainer
20	1	Bonnet
19	1	Spring Pin
18	1	Handle Safety Lock
17	1	Stem Spring
16	1	Stem
15	1	Body/Bonnet Seal
14	15	Stem Centering Bushing
13	1	Stem Extension Guide Nut
12	1	Body (Angle)
11	1	Body/Nozzle Seal
10	1	Stem Extension
9	1	Disc Holder
8	1	Nozzle
7	1	Sleeve
6	1	Inlet Label
5	1	Nozzle/Seat Seal
4	1	Seat
3	1	Disc Washer
2	2	Hex Jam Nut
1	1	Disc (Nitrile)
Item	Qty	Description